



Schaltbild  
Circuit  
Diagram  
Schema

ⓓ Btx \* 32700 #

### CUC 5303

P 37 - 040 a (9.25987-01)

P 40 - 050 (9.25986-01)

P 37 - 050 (9.25988-01)

ⓓ

## Abgleichvorschriften

Alle nicht beschriebenen Einstellelemente sind werksseitig abgeglichen und dürfen im Service-Fall nicht verstellt werden.

### 1. Chassis

**1.1 Regelspannungsverzögerung (Tuner)**  
Normtestbild auf hohen UHF Kanal legen, die HF sollte mindestens 1,5 mV (60 dB $\mu$ V, rauschfreies Bild) betragen. Regler R 152 (Kontakt 9, ZF-Verst.) drehen bis das Bild zu rauschen beginnt, dann wieder zurückdrehen bis das Bild gerade rauschfrei wird.

**1.2 Abgleich der Zeilenfrequenz**

- FBAS Sync. an C 163 nach Masse kurzschließen.
- Mit dem Einstellregler R 506 Bild auf langsames Durchlaufen einstellen.
- Kurzschluß entfernen.

### 2. Bildrohrplatte

**Weißabgleich**

- FuBK - Testbild einspeisen.
- ⓐ min., ○ nom., ● max. einstellen.
- Regler VG und VB (Bildrohrplatte) so einstellen, daß keine Verfärbungen in den Grauwerten sichtbar sind.

### 3. Farb/ RGB

Servicearbeiten nach Bausteinwechsel: -

Abgleich:

**1. Sperrpunktgleich**

- FuBK-Testbild einspeisen.
- ⓐ min., ○ nom., ● min. einstellen.
- Tastkopf an den Kollektoren der Transistoren T 736, T 756, T 776 anhängen (Bildrohrplatte). Die Schwarzwerte der drei Kathodensignale liegen bei ca. 140...150 V.

**2. Abgleich der Farbverarbeitung**

- (Bei allen Messungen Tastkopf 10 : 1, um Belastungen zu vermeiden).
- PAL-Testbild einspeisen.
  - Das Filter F 2512 ist vom Werk richtig abgeglichen und sollte nicht verstellt werden.

ⓐ

## Adjustment procedures

All adjustment controls not mentioned in this description are adjusted during production and must not be re-adjusted in the case of repairs.

### 1. Chassis

**1.1 Delayed Automatic Gain Control Voltage (Tuner)**

Feed in a standard test pattern at a channel in the upper range of the UHF Band. The RF should be at least 1,5 mV (60 dB $\mu$ V, noise free picture). Rotate the control R 152 (contact 9, IF-Ampl.) until noise just begins to appear in the picture, then reverse the direction of the control until the picture just becomes noise free.

**1.2 Adjustment of Line Frequency**

- Short circuit FBAS Sync. at C 163 to chassis.
- With the adjustment control R 506, adjust so that the picture runs through slowly.
- Remove the short circuit.

### 2. CRT base

**White Alignment:**

- Feed in a FuBK Test Pattern.
- Adjust ⓐ to min., ○ to nom., ● to max.
- Adjust the controls VG and VB (Picture Tube panel) so that no colouration is visible in the Grey Value areas.

### 3. Color/RGB

Service work after replacing the module: -

Alignment:

**1. Cut-off point alignment**

- Feed in a FuBK Test Pattern.
- Adjust ⓐ to min., ○ to nom., ● to min.
- Connect test probe to collectors of the transistors T 736, T 756, T 776 (picture tube panel). The black level of the three cathodes will be at approx. 140...150V.

**2. Adjustments for colour processing**

- (Set the test probe to 10:1 for all measurements to avoid loading errors).
- Feed in a PAL Test Pattern.
  - The filter F 2512 has been correctly set in manufacture and should not be readjusted.

ⓓ

## Taratura

Tutti i componenti non descritti, sono stati tarati in fabbrica e non devono essere regolati in caso di servizio.

### 1. Telaio

**1.1 Ritardo della tensione di regolazione (Tuner)**

Porre il monoscopio su un canale UHF elevato, il segnale AF deve essere almeno 1,5 mV (60 dB $\mu$ V, immagine priva di fruscio). Ruotare il regolatore R 152 (contatto 9, Ampl. FI) l'immagine comincia ad apparire frusciosa, successivamente girarlo in senso opposto finchè nell'immagine scompare il fruscio.

**1.2 Taratura della frequenza di riga**

- Cortocircuitare verso massa il C 163 FBAS Sync.
- Regolare R 506 finchè l'immagine scorre lentamente.
- Togliere il cortocircuito.

### 2. Piastra cinescopio

**Taratura del bianco:**

- Applicare un monoscopio FuBK.
- Regolare ⓐ al minimo, ○ sul valore nominale e ● al massimo.
- Con VG e VB (piastra cinescopio) eliminare eventuali macchie di colore visibili su tutta la scala dei grigi.

### 3. Colore/RVB

Lavori da eseguire dopo la sostituzione del modulo: --

Taratura:

**1. Taratura del punto di interdizione**

- Applicare un monoscopio FuBK.
- Regolare ⓐ al minimo, ○ sul valore nominale e ● al minimo.
- Collegare la sonda ai collettori dei transistori T 736, T 756, T 776 (piastra cinescopio). Il valore del nero dei tre segnali catodici sono a ca. 140...150V.

**2. Taratura nel canale croma:**

(Impiegare una sonda 10:1 per tutte le misure, in modo da evitare carichi).

- Abgleich des Farbtraps:  
Tastkopf an Pin 8 des IC 2541 (TDA 3562), den Farbträger mit dem Filter F 2524 auf Minimum stellen.
- Pin 1 mit Pin 5 und Pin 24 mit Pin 25 des IC 2541 (TDA 3562) verbinden.
- Mit Trimmer C 2582 die durchlaufenden Farbbalken zum Stehen bringen.
- Kurzschlußbrücken entfernen.
- Den Tastkopf an Pin 17, des IC 2541 einhängen.
- Durch wechselseitigen Abgleich des Filters F 2531 (LZ) und des Reglers R 2533 (BP) die Doppelbilder des B-Signals zur Deckung bringen.  
Hinweis: Mit F 2531 (B-Y) beginnen.

- Colour trap alignment:  
Connect a test probe to pin 8 of IC 2541 (TDA 3562) and adjust filter F 2524 so that the colour carrier is at minimum.
- Connect pin 1 to pin 5 and pin 24 to pin 25 of IC 2541 (TDA 3562).
- Adjust trimmer C 2582 so that the colour bars which are running through are stationary.
- Remove the short-circuits.
- Connect the test probe to pin 17 of IC 2541.
- By adjusting the filter F 2531 (LZ) and the control R 2533 (BP) alternately, make the double images produced by the B - signal to coincide.  
Note: Commence with F 2531 (B-Y).

- Applicare un monoscopio PAL.  
Il filtro F 2512 viene tarato al valore giusto in fabbrica e non deve essere modificato.
- Taratura della trappola colore:  
Collegare una sonda dell'oscilloscopio al pin 8 di IC 2541 (TDA 3562), con F 2524 tarare il segnale sul minimo della portante colore.
- Collegare pin 1 il pin 5 e pin 24 il pin 25. dei IC 2541 (TDA 3562).
- Con C 2582 fermare le bare colorate scorrevoli.
- Togliere i cortocircuiti.
- Collegare la sonda al pin 17 dell'integrato IC 2541.
- Con taratura viceversa del filtro F 2531 e del regolatore R 2533 portare a copertura le immagini doppie del segnale B. Iniziare con filtro F 2531.

## Schaltplansymbole / Circuit diagram symbols / Simboli sullo schema

 Zeilenbreite / Line width / Amplitude horizontale / Larghezza di riga / Amplitudo Horizontal

 Hor. Frequenz / Hor. Frequency / Fréqu. horiz. / Freq. orizz. / Freq. horiz.

 Hor. Linearität / Hor. linearty / Linéar. Horizont / Linear. orizz. / Lineal. Horizontal

 Bildlage hor. / Hor. picture position / Cadrage horizont. / Posizione orizz. d'immagine / Centrado horizontal

 Ost-West Amplitude / East-West amplitude / Amplitude Est - Ouest / Ampiezza Est-Ovest / Amplitud E-O

 Ost-West Symmetrie / East-West symm. / Symm. Est-Ouest / Simm. Est-Ovest / Simetria E-O

 Bildamplitude / Frame ampl. / Ampl. verticale / Ampiezza d'immagine / Ampl. vertical

 Vert. Frequenz / Vert. frequency / Fréqu. vert. / Freq. vert. / Freq. vert.

 Vert. Linearität / Vert. linearity / Linéarité vert. / Linear. vert. / Linealidad vert.

 Bildlage vert. / Vert. picture position / Cadrage vertical / Posiz. vert. d'immagine / Centrado vert.

 Focusregler / Focus control / Réglage de focalisation / Regolat. di focalizz. / Control de foco

 Trapez / Trapezium / Trapèze / Trapezio / Trapecio

## Oszillogramme - Chassis / Oscillogrammes chassis / Oszillogrammi telaio

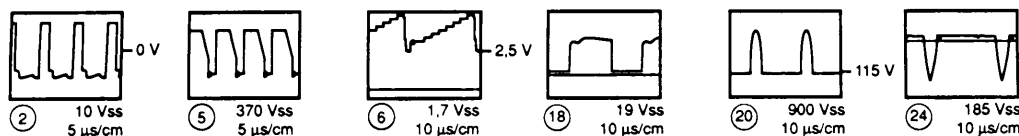

## Modulübersicht / Module List / Sommario delle moduli

	P 37 - 040 a	P 37 - 050	P 40 - 050
Bildrohrplatte CRT Base Piastra cinescopio	29305-022.04	29305-022.04	29305-022.05
Farb/RGB Colour/RGB Colore/RVB	29504-105.14	29504-105.14	29504-105.14
Tuner	29504-101.22	29504-101.22	29504-101.22
ZF-Verstärker IF amplifier Amplificatore de FI	29504-102.71	29504-102.26	29504-102.26

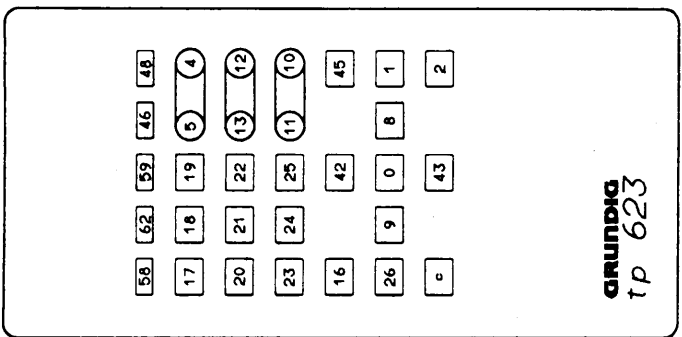
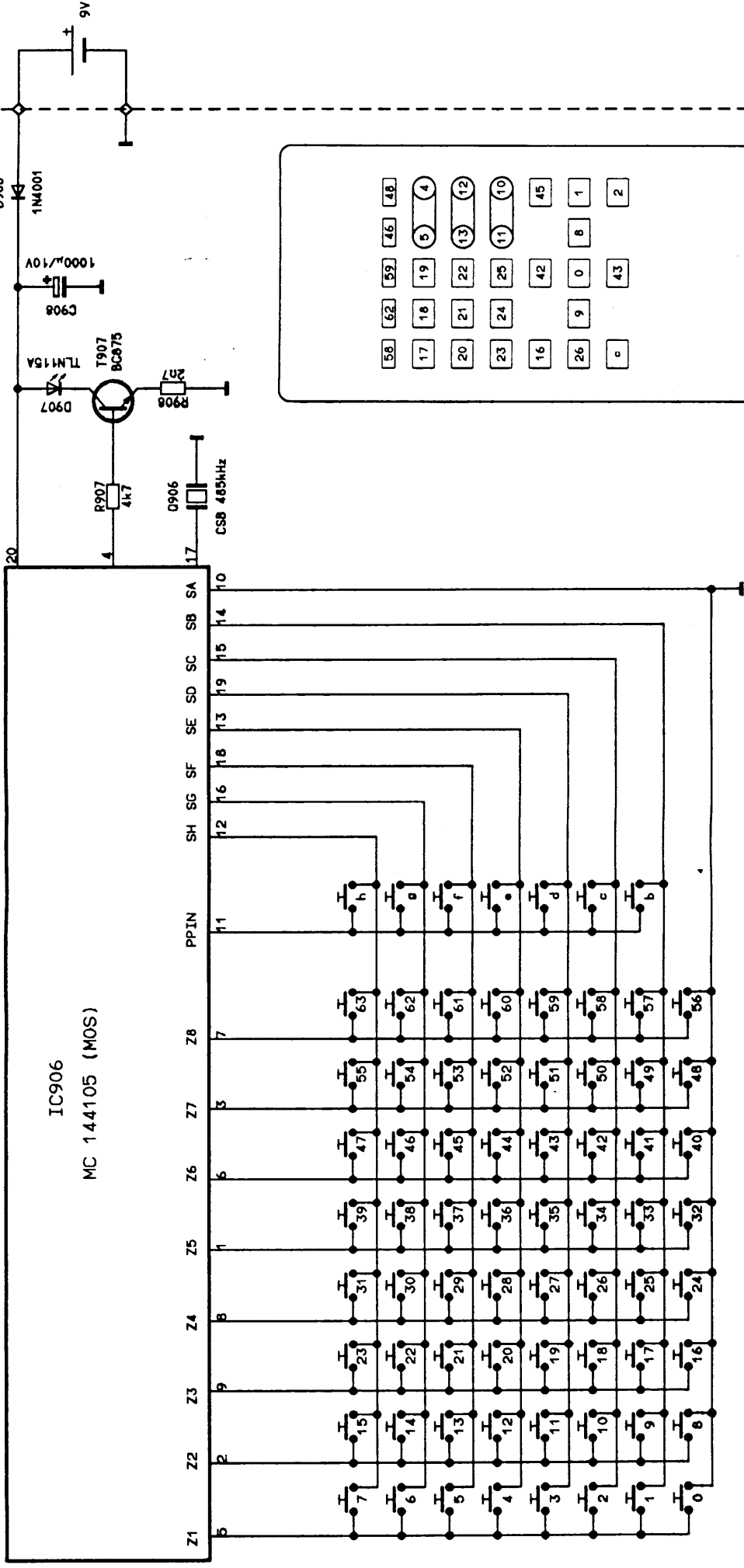

KEYBOARD  
 KEYBOARD  
 CLAVIER  
 KEYBOARD  
 TECLADO

GRUNDIG  
 tp 623

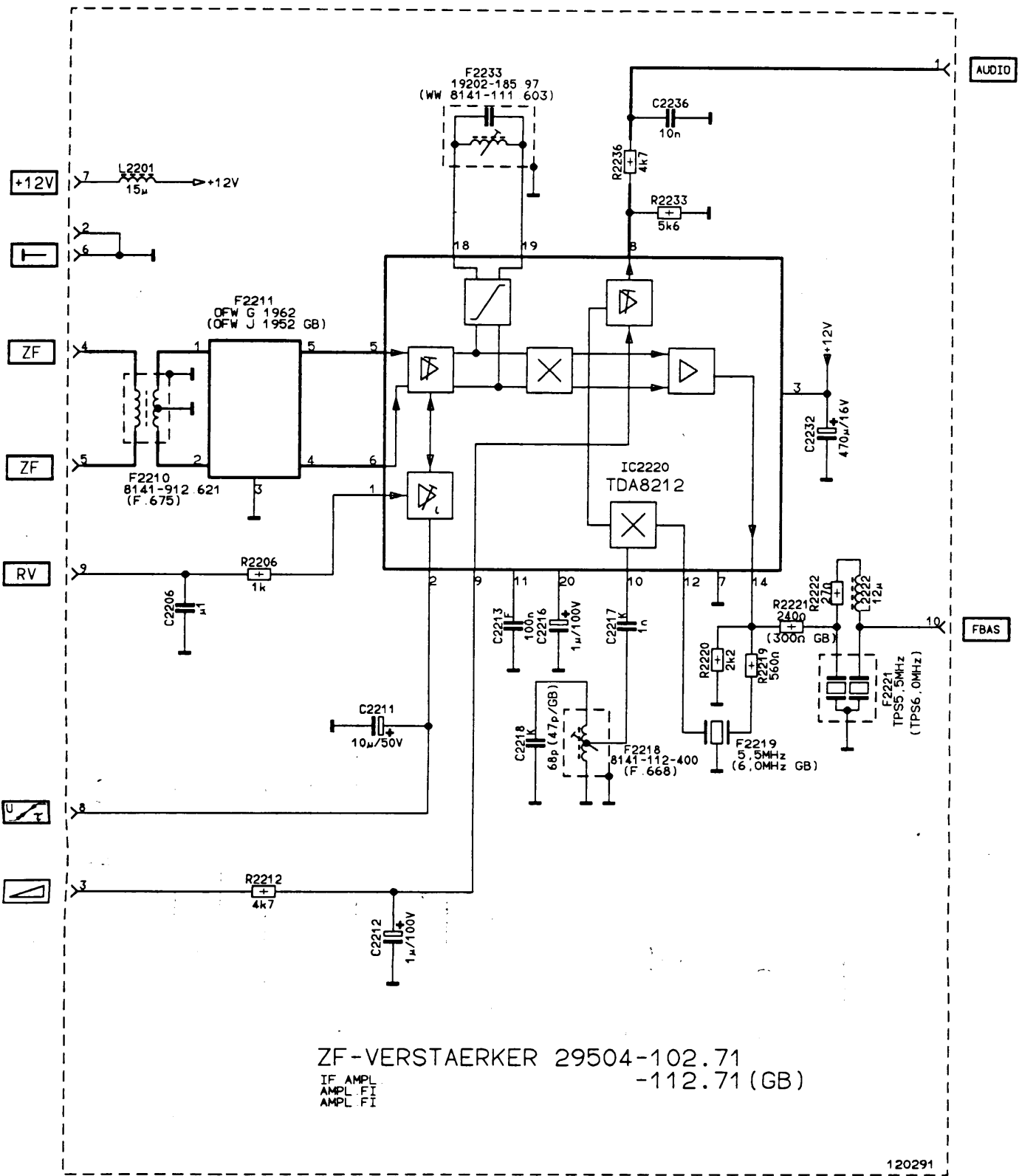

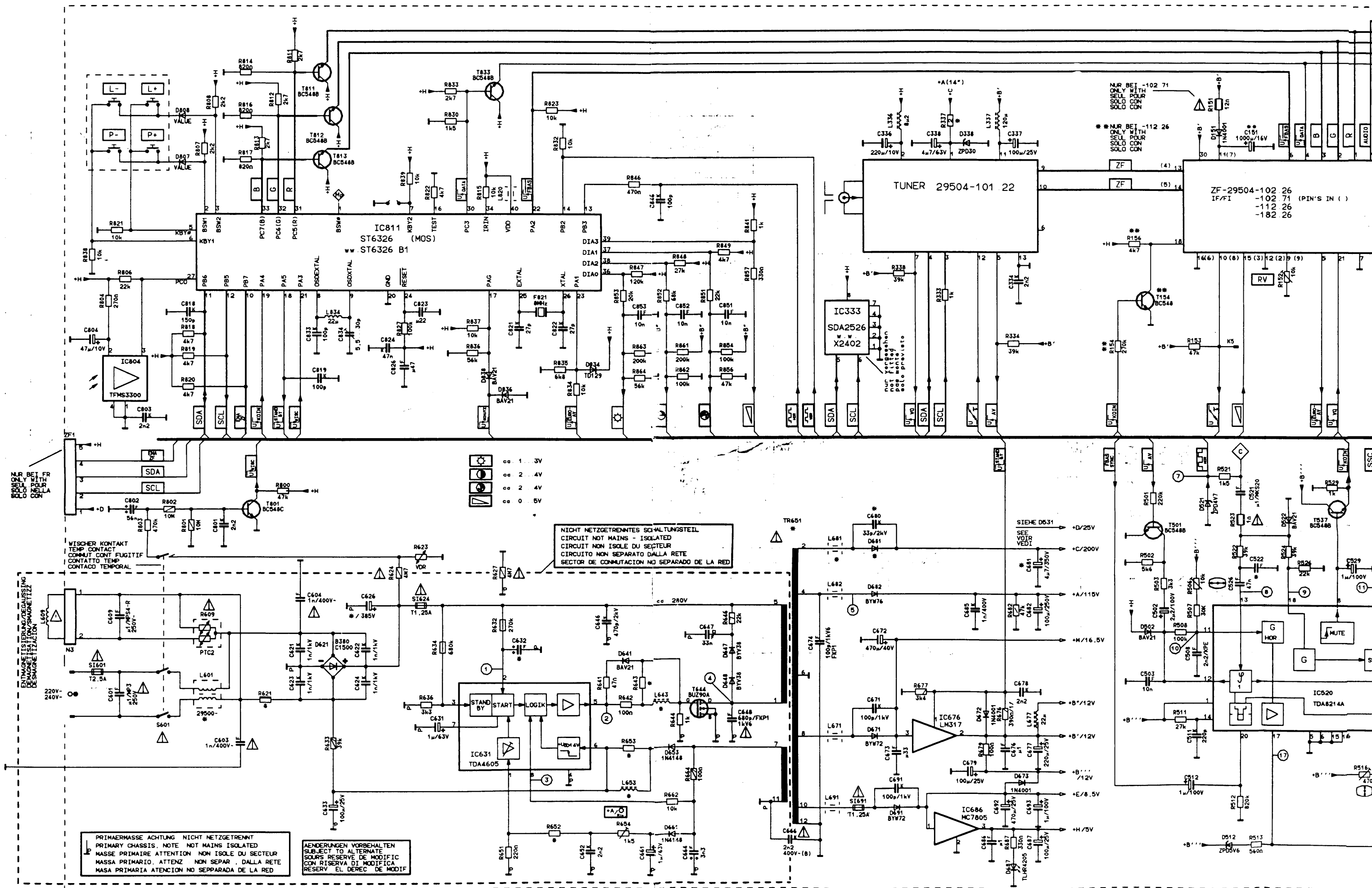

SOUS-RESEAU SEUL  
ONLY WITH  
COLOR  
ONLY WITH  
COLOR

ENTRAMETTIERUNG/DEGAUSSING  
ONLY WITH  
COLOR  
ONLY WITH  
COLOR

WISCHER KONTAKT  
TEMP CONTACT  
COMMUT. CONT. FUGITIF  
CONTATTO TEMP.  
CONTACTO TEMPORAL

NICHT NETZGETRENNTES SCHALTUNGSTEIL  
CIRCUIT NOT MAINS - ISOLATED  
CIRCUITO NON ISOLE DU SECTEUR  
CIRCUITO NON SEPARATO DALLA RETE  
SECTOR DE CONMUTACION NO SEPARADO DE LA RED

PRIMAERMASSA ACHTUNG NICHT NETZGETRENNT  
PRIMARY CHASSIS. NOTE NOT MAINS ISOLATED  
MASSE PRIMARIE ATTENTION NON ISOLE DU SECTEUR  
MASA PRIMARIO, ATENCIÓN NON SEPAR. DALLA RETE  
MASA PRIMARIA ATENCIÓN NO SEPARADA DE LA RED

ÄNDERUNGEN VORBEHALTEN  
SUBJECT TO ALTERNATE  
SOURS RESERVE DE MODIFICA  
CON RISERVA DI MODIFICA  
RESERV. EL DEREC. DE MODIF

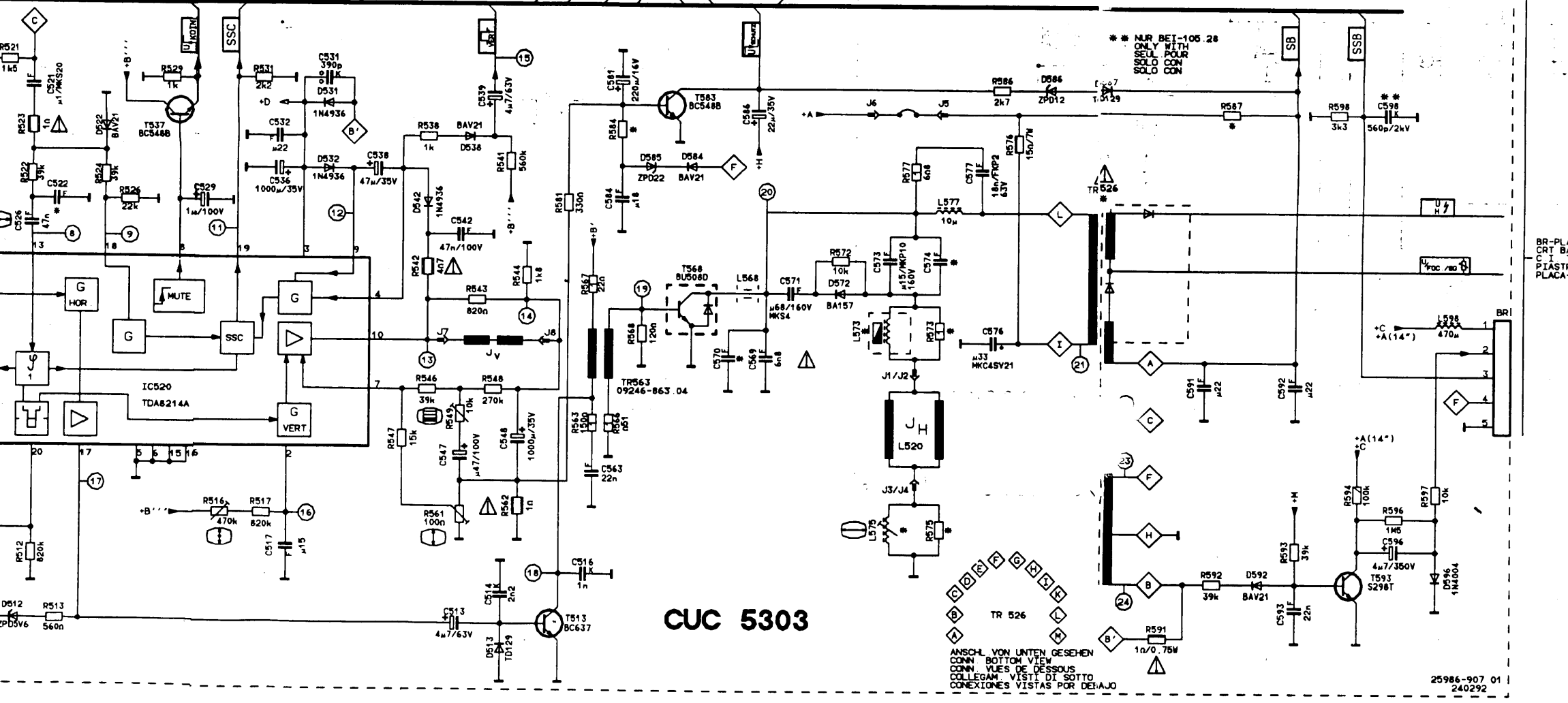
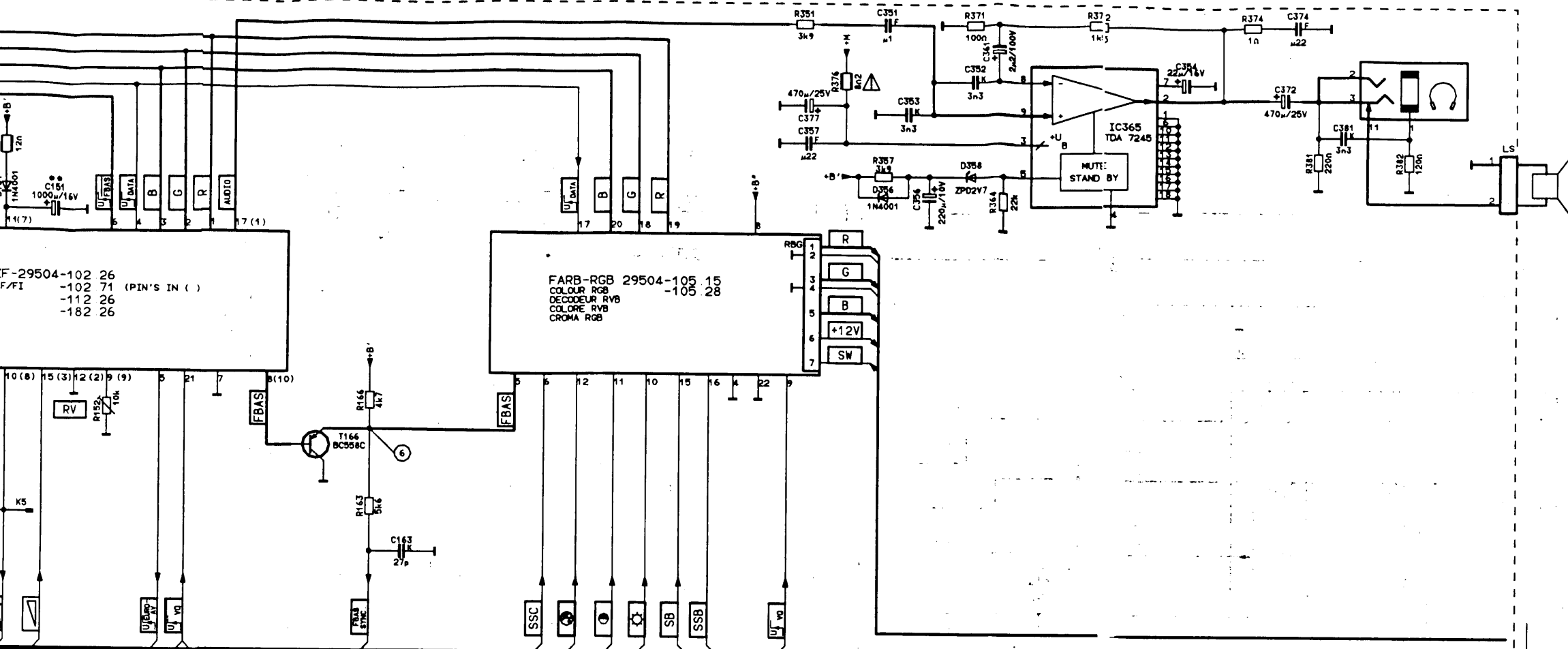

#	14°	15°	16°	17/19/21°	20°PHILIPS	20°YOSHIDA (R10N)
R584	1k5	2k2	2k2	2k2	2k2	2k2
R652	5k1	4k7	5k6	5k6	5k6	5k6
L601	29500-811 97	-811 97	-811 97	-812 97	-812 97	-812 97
R621	↔	↔	↔	2n2/7W	2n2/7W	2n2/7W
L681	↔	↔	↔	↔	↔	↔
C680	↔	33p/2kV	33p/2kV	33p/2kV	33p/2kV	33p/2kV
D681	↔	BYV38	BYV38	BYV38	BYV38	BYV38
C681	↔	4μ7/350V	4μ7/350V	4μ7/350V	4μ7/350V	4μ7/350V
C570	↔	↔	↔	↔	↔	750p
R573	↔	820n	820n	820n	820n	820n
L573	↔	29203-115 97	-115 97	-115 97	-115 97	-115 97
C574	μ27/MKP10	μ1/MKP10	μ27/MKP10	μ1/MKP10	μ27/MKP10	μ27/MKP10
R575	↔	1k5/4W	820n/2W	1k5/4W	820n/2W	820n/2W
L575	↔	09246-850 21	-838 21	-850 21	-838 21	-838 21
TR651	29201-322 97	-327 97	-327 97	-327 97	-327 97	-327 97
TR526	29201-028 03	-028 04	-028 04	-028 04	-028 04	-028 04
R337	18k	33k	33k	33k	33k	33k
R587	680k	390k	390k	390k	390k	390k
C522	6n8	4n7	4n7	4n7	4n7	4n7
C632	4n7	6n8	6n8	6n8	6n8	6n8
L643	68μ	↔	↔	↔	↔	↔
R643	82n	↔	↔	↔	↔	↔
L653	68μ	↔	↔	↔	↔	↔
R653	220n	↔	↔	↔	↔	↔
R654	1k2	1k5	1k5	1k5	1k5	1k5
C626	100μ	150μ	150μ	150μ	150μ	150μ

BR-PLATTE 29305-022 01 20°  
 CRT BASE 03 14°  
 C I TUBE CATHOD 04 14°  
 PLASTRA CINESC  
 PLACA-ZOCALO TRC

CUC 5303

ANSCHL. VON UNTEN GESEHEN  
 CONN. BOTTOM VIEW  
 CONN. VUES DE DESSOUS  
 COLLEGAM. VISTI DI SOTTO  
 CONEXIONES VISTAS POR DEBAJO

25986-907 01  
 240292

#	R2502	C2522	R2541	R2542	C2562 C2564 C2566	R2562 R2564 R2566	R2501	R2572 R2573	R2574 R2576	R2586	R2592	IC2541
-102 14	220k	100p	470n	560n	68p	1x5	10k	10k	μ47	15k	13k	TDA3562
-105 15	—	82p	560n	470n	82p	1x2	68k	22k	μ22	68k	13k	TDA3566

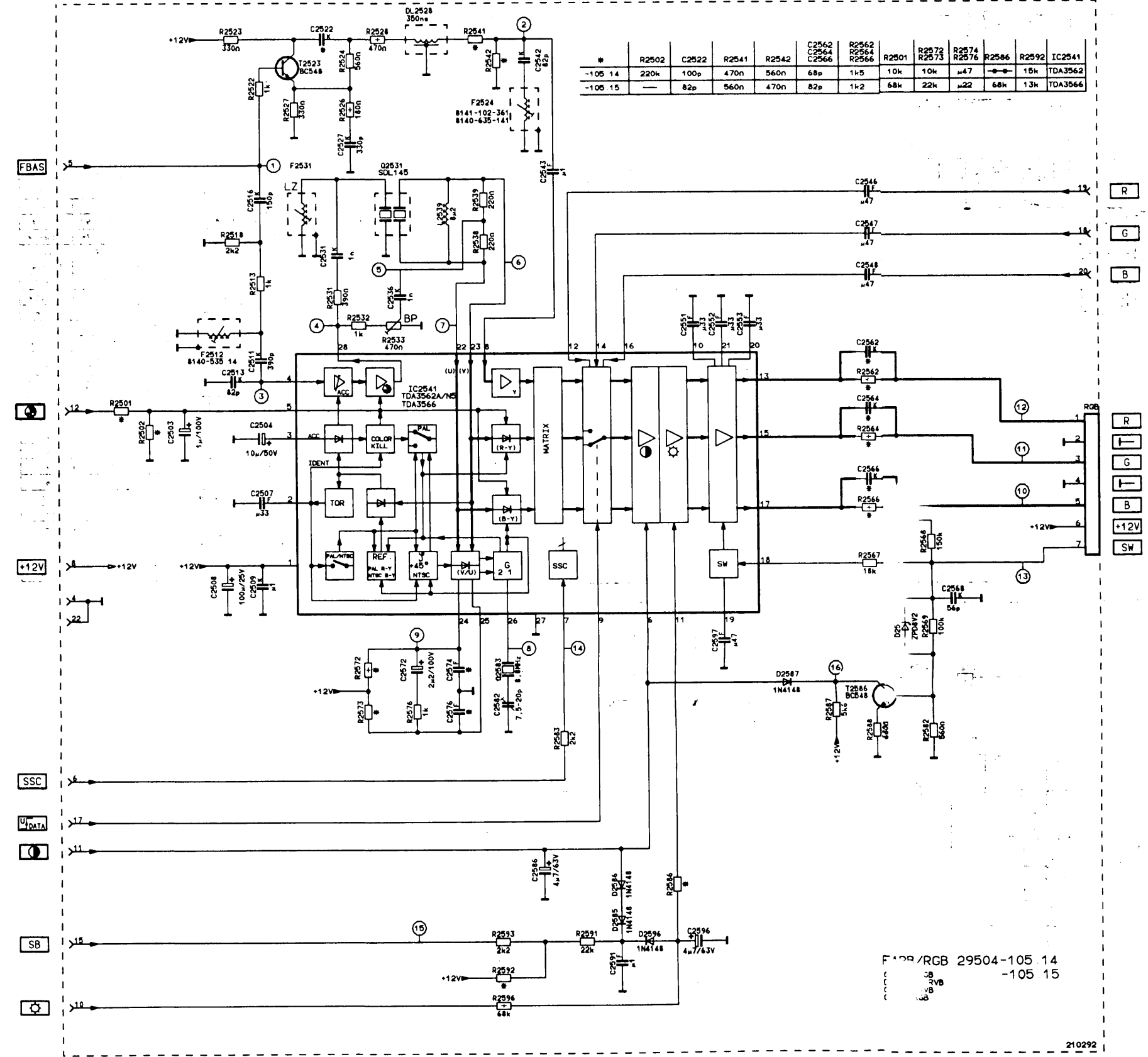

F12P/RGB 29504-105 14  
-105 15

210292

#	F2233	F2232	F2234	R2236	L2236	F2235	C2218	C2219	F2217	R2217	C2220	C2217	F2202
-102 26	SFE5.5MHz	—	TPS5 B	—	—	8141-112-405	1n	—	—	—	—	58p	G1962
-112 26	SFE6.0MHz	—	TPS6 0	10n	8μ2	—	—	—	—	—	—	47p	J1952
-182 26	SFE5.5MHz	SFE6.5MHz	TPS5 B	—	—	8141-112-405	—	1n	8141-112-668	VALUE	27p	58p	K2950

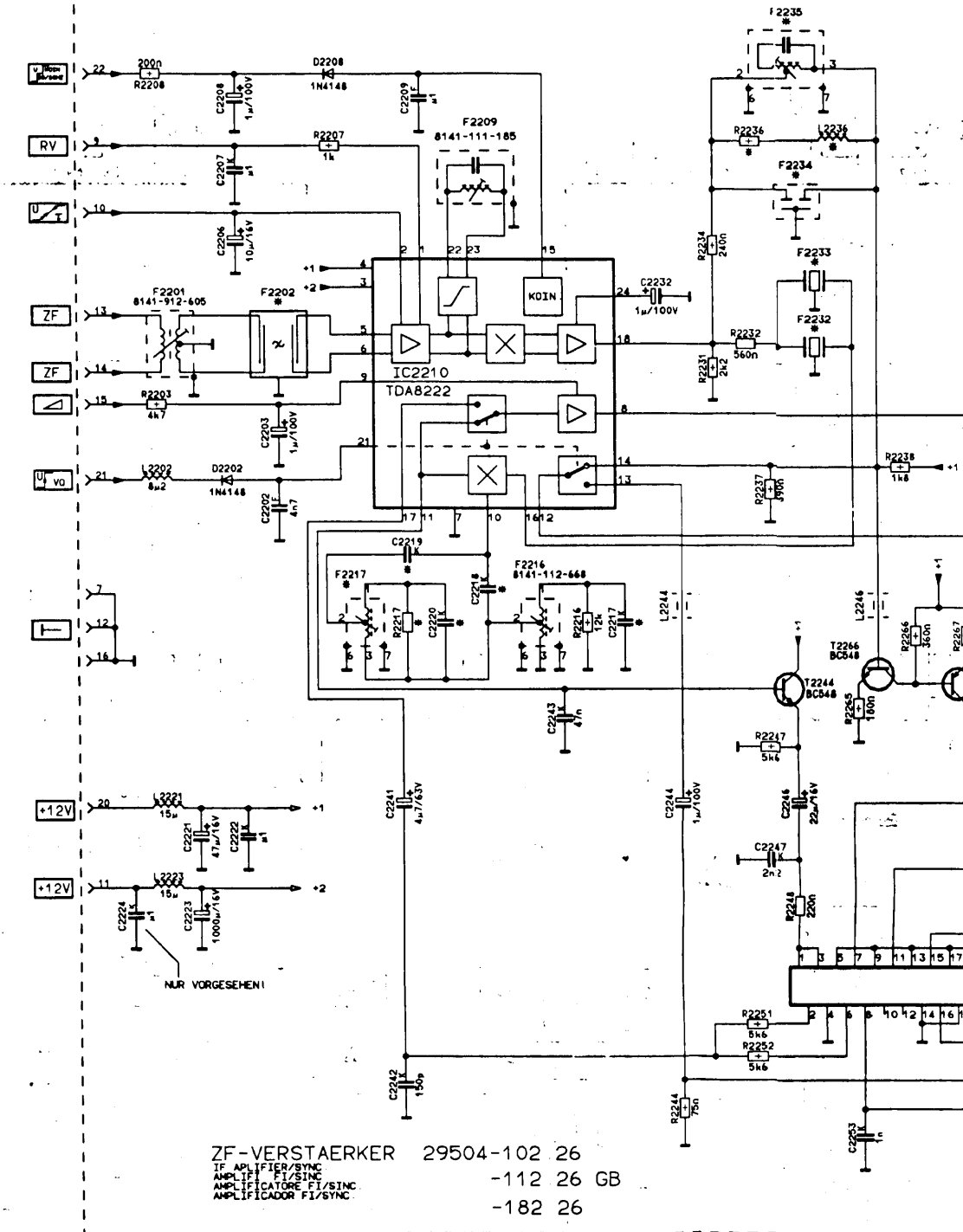

ZF-VERSTÄRKER 29504-102 26  
IF AMPLIFIER/SYNC -112 26 GB  
AMPLIFICATORE FI/SINC  
AMPLIFICADOR FI/SINC -182 26

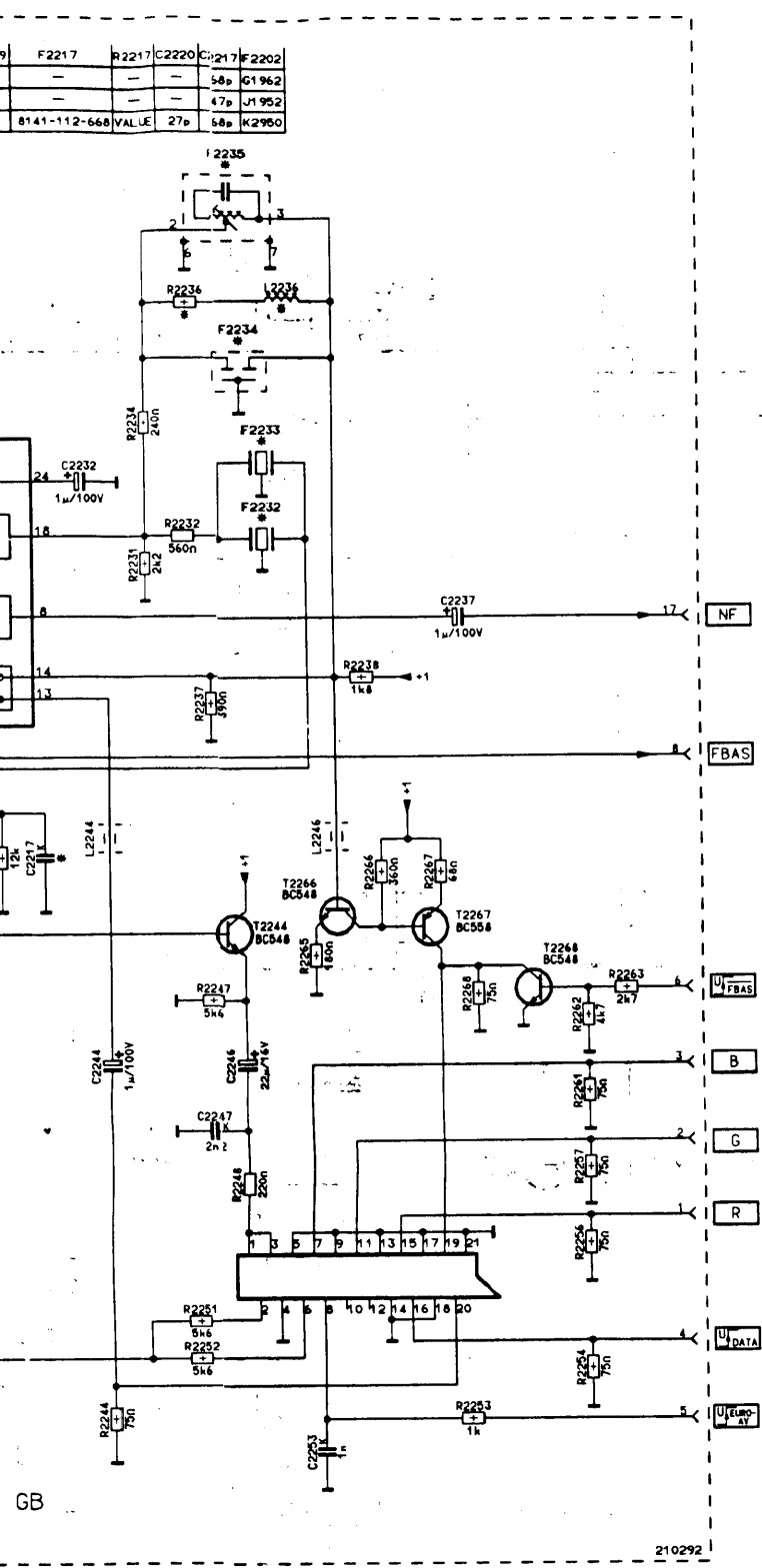

210292

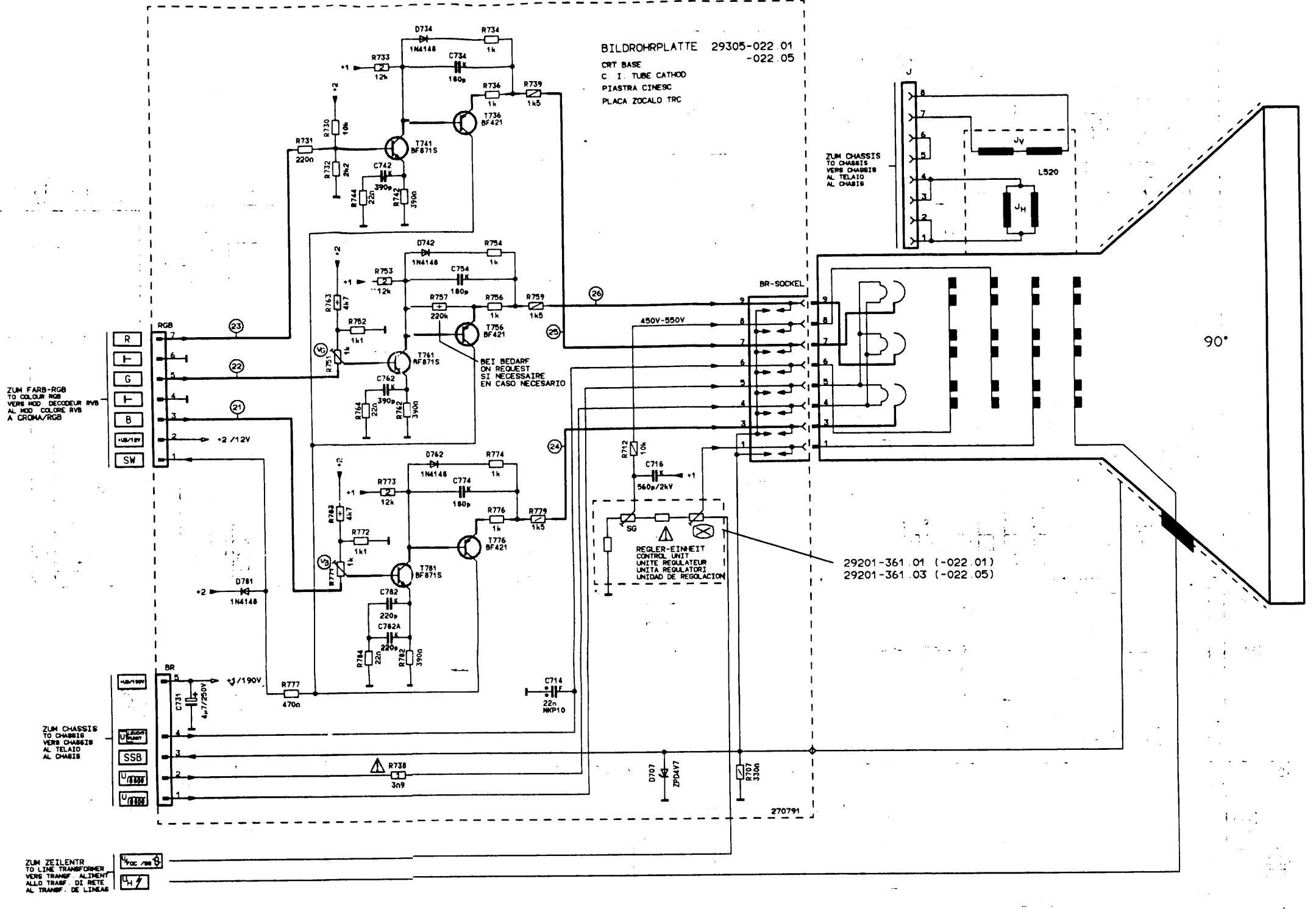



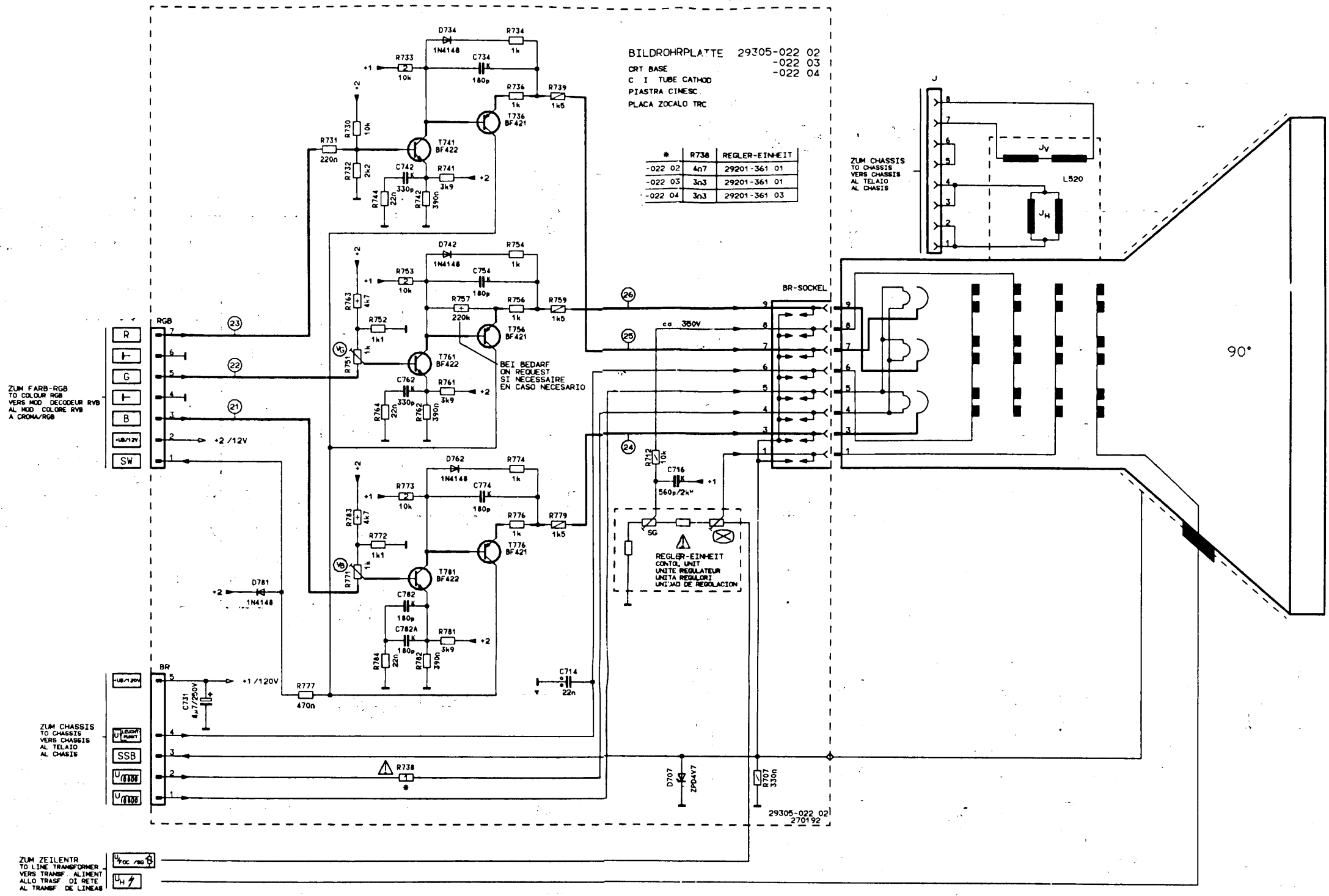

TUNER 29504-101.21  
 -101.22  
 -131.23 (ARGENTINIEN)

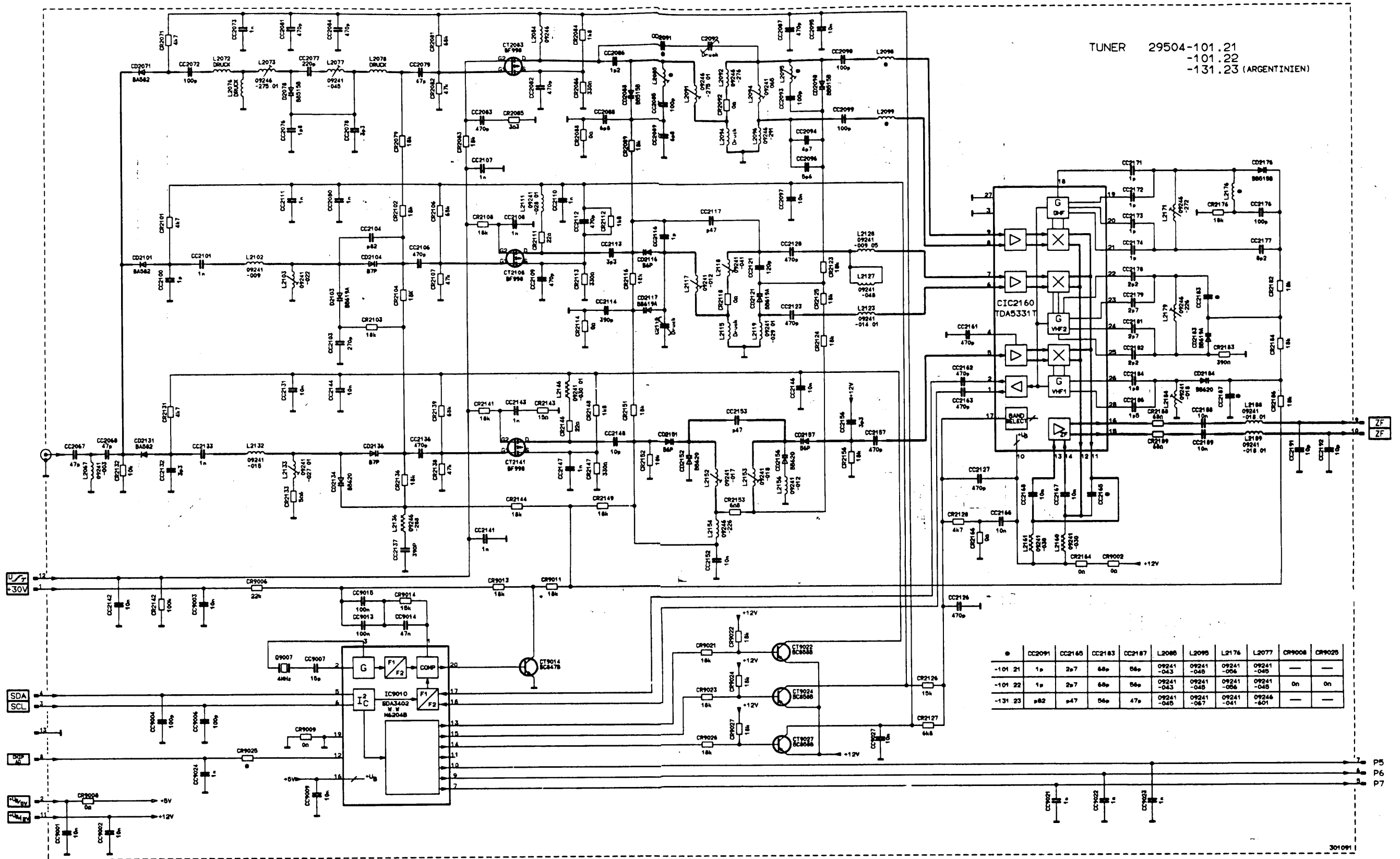

	CC2091	CC2165	CC2183	CC2187	L2086	L2095	L2176	L2077	CR9006	CR9025
-101 21	1p	2p7	68p	56p	09241-043	09241-045	09241-058	09241-045	—	—
-101 22	1p	2p7	68p	56p	09241-043	09241-045	09241-056	09241-045	On	On
-131 23	p82	p47	56p	47p	09241-045	09241-067	09241-041	09244-601	—	—